

LC588 TYRE CHANGER SPECIFICATIONS

A-20

ITEM	QTY.	PART NO.	DESCRIPTION.	ITEM	QTY.	PART NO.	DESCRIPTION.
1	1	6001011	MAIN SHAFT	36	6	5004046	WASHER 8
2	1	6000950	VERTICAL MOVABLE ARM SUPPORT SHAFT	37	1	6001087	TOOL BOX
3	1	6001001	CIRCULAR GUIDERAIL WAHER	38	4	5000061	BOLT M8X35
4	1	5006041	BOLT M12X30-N	39	8	5004008	NUT M6
5	2	6000951	VERTICAL MOVABLE ARM LINK SHAFF	40	6	5010043	WASHER 6
6	1	6001149	VERTICAL MOVABLE ARM BACK COVER	41	3	5000057	BOLT M6X16-N
7	7	5000051	BOLT M8X16	42	3	5010058	WASHER 6
8	5	5000055	WASHER 8	43	1	6001066	SHAFT
9	1	6000932	WELDING VERTICAL MOVABLE ARM	44	6	5010109	CIRCLIP 24
10	2	6000948	BEARING BUSHING	45	1	6001109	CYLINDER
11	4	5000089	BOLT M10X40	46	1	6001084	OPERATION DESK
12	25	5004041	WASHER 10	47	8	5010006	WASHER 10
13	8	5010004	NUT M10	48	4	5004009	TYPE21 M10X25-25-N
14	2	5010029	BOLT M10X50	49	1	6001156	HYDRAULIC UNIT
15	1	5000053	PLAIN KEY 8X32	50	1	6000904	Body Welding
16	1	6001150	BELT PULLEY BELT	51	1	6001006	CYLINDER COVER
17	2	5000062	TRIANGLE BELT A710	52	1	6000952	TRAILER ASSEMBLY
18	2	6001058	CONNECTING PIN	53	1	6001098	CYLINDER
19	1	6001056	SMALL BELT PULLEY	54	2	5004222	NUT M16-N
20	2	5000067	SCREWS M10X30-25	55	2	6001064	ROLLER
21	1	5000054	SCROW M6X14	56	2	5000059	SCREW m16x80
22	1	6001053	MOTOR BELT PULLEY COVER PLATE	57	3	5004020	BOLT M10X25
23	1	6001051	SUPPORT BRACKET	58	1	6001059	BACLING PLATE ASSEMBLY WELDING
24	1	5500006	MOTOR 380V	59	1	6001071	ELECTRICAL CABINET
25	6	5000056	SCREW M10X45-N	60	1	6001070	VALVE COVER
26	1	6001154	MAIN SHAFT OIL TANK	61	4	6001069	DOUBLE ROD SCREW
27	1	5000049	NUT M24-N	62	1	5500038	24INCH CROWBAR
28	1	6001200	WORM BOX	63	1	5500040	PRESSURE-PROOF RUBBER HOSE L1800
29	4	5004013	WASHER 5	64	1	5500060	PRESSURE-PROOF RUBBER HOSE L1850
30	1	6001045	WELDING MAIN SHAFT OIL TANK HOOK	65	2	5500059	PRESSURE-PROOF RUBBER HOSE L1000
31	8	5000048	SCREW M6X10-N	66	2	5500061	PRESSURE-PROOF RUBBER HOSE (AT TERMINAL) L1200
32	2	6001044	SUPPORT ANGLE IRON	67	4	5000060	ACORN NUT M6-N
33	1	5500039	TOOL BOX COVER	68	4	5009041	WASHER 12
34	1	6001157	WELDING MAIN SHAFT OIL TANK HOOK	69	1	5004094	CROWBAR
35	8	5002060	NUT M8	70	1	5509111	SCREW M6X10

6000952 TRAILER ASSEMBLY

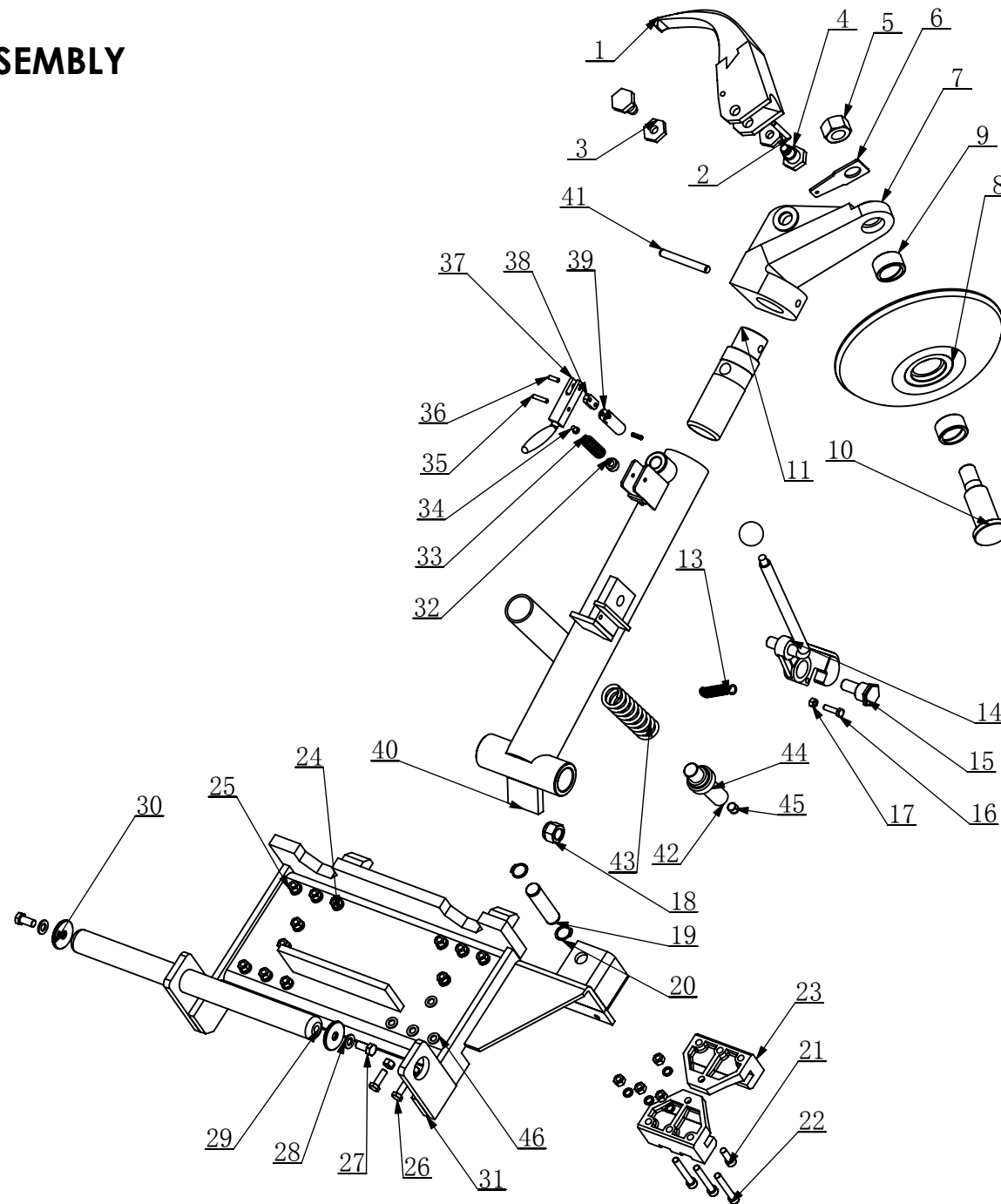

6000952 TRAILER ASSEMBLY

A-19

ITEM	QTY.	PART NO.	DESCRIPTION.	ITEM	QTY.	PART NO.	DESCRIPTION.
1	1	6000985	SHARP-NUSE TOOL	31	1	6000945	TRAILER ASSEMBLY WELDING
2	1	6000986	PIN	32	1	6000974	POSITION STUD
3	2	6000988	NUT	33	1	5000118	SPRING
4	2	6000987	SCREW-FIX	34	1	5000023	SCREWS M6X10
5	1	5000027	NUTS M27	35	1	5000025	PIN 6X30
6	1	6000991	EXTENSION SPRING CONNECT PLATE	36	2	5000024	PIN 6X20
7	1	6000992	DOUBLE TOOL SUPPORT	37	1	6000970	FIX LOCK PRESSER
8	1	6000993	TURNTABLE	38	1	6001180	FIX LOCK PRESSER
9	2	6000976	BEARINGS	39	1	6000973	PIN-FIX
10	1	6000989	CORE SHAFT	40	1	6000957	TOOL SUPPORT
11	1	6000990	CONNECT SHAFT	41	1	5000028	PIN 12X100
12	1	5010005	HANDBALL	42	1	6000947	TRAILER PLANE
13	1	6002067	EXTENSION SPING	43	1	6000984	PRESS SPRING
14	1	6008909	TIGER HOOK	44	1	6000983	NUT BUSHING
15	1	6000979	ECCENTRIC SHAFT	45	1	6000981	WASHER
16	1	5000030	BOLT M8X30	46	16	5004221	WASHER 10
17	1	5002060	NUT M8				
18	1	5000026	NUT M20X1.5				
19	1	6000997	SHORT PIN SHAFT				
20	2	5010109	CIRCLIP 24				
21	4	5000033	SCREW M10X30				
22	12	5000034	SCREW M10X70				
23	4	6000956	GUIDERAIL SUPPORT				
24	16	5010006	WASHER 10				
25	20	5010004	NUT M10				
26	4	5000022	BOLT M10X30				
27	2	5000020	BOLT M12X25				
28	2	5000021	WASHER 12				
29	1	6001002	TRAILER CIRCULAR GUIDERAIL				
30	2	6001001	CIRCULAR GUIDERAIL WAHER				

6001011 PRINCIPAL AXIS ASSEMBLY

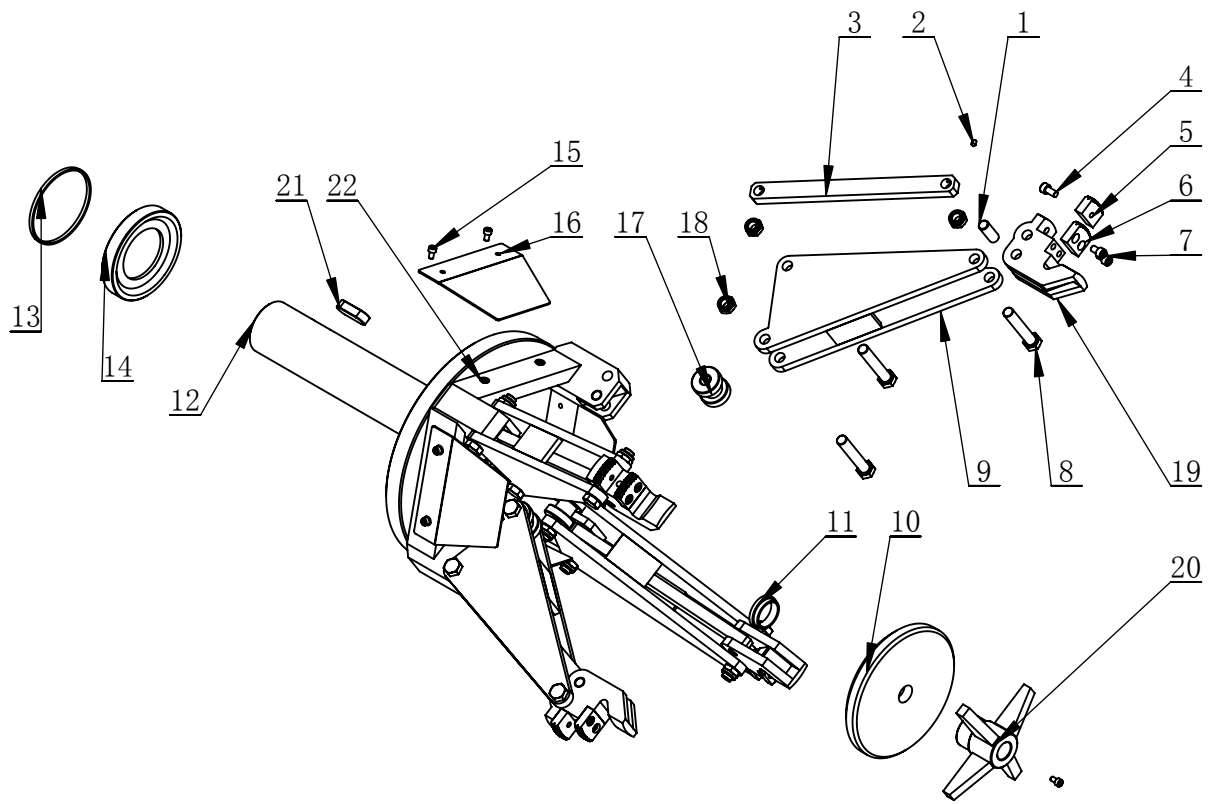

6001011 PRINCIPAL AXIS ASSEMBLY

ITEM	QTY.	PART NO.	DESCRIPTION.
1	8	6001023	PIN SHAFT
2	8	5000001	SCREW M6X8
3	4	6001024	PULLING PLATE
4	4	5000002	SCREW M8X16
5	4	6001025	GRIPPING CLAW A
6	4	6001026	GRIPPING CLAW B
7	8	5000003	SCREW M8X12
8	12	5000004	BOLT M14X80
9	4	6001018	CLAMP SUPPORT
10	1	6001022	PAD
11	1	6001030	PROTECTION BUSHING
12	1	6001012	SPINDLE
13	1	5500001	FELT D110Xd105X5
14	1	6001031	EXTERNAL FURREUL OF MAIN SHAFT
15	9	5004220	SCREW M6X10-N
16	4	6001048	GUIDE PLATRE
17	4	6001028	ROLLER
18	12	5000006	NUT M14
19	4	6001027	GRIPPING CLAW
20	1	6001021	SUPPORT BRACKET
21	1	5000008	KEY 20X56
22	9	5000007	WASHER 6

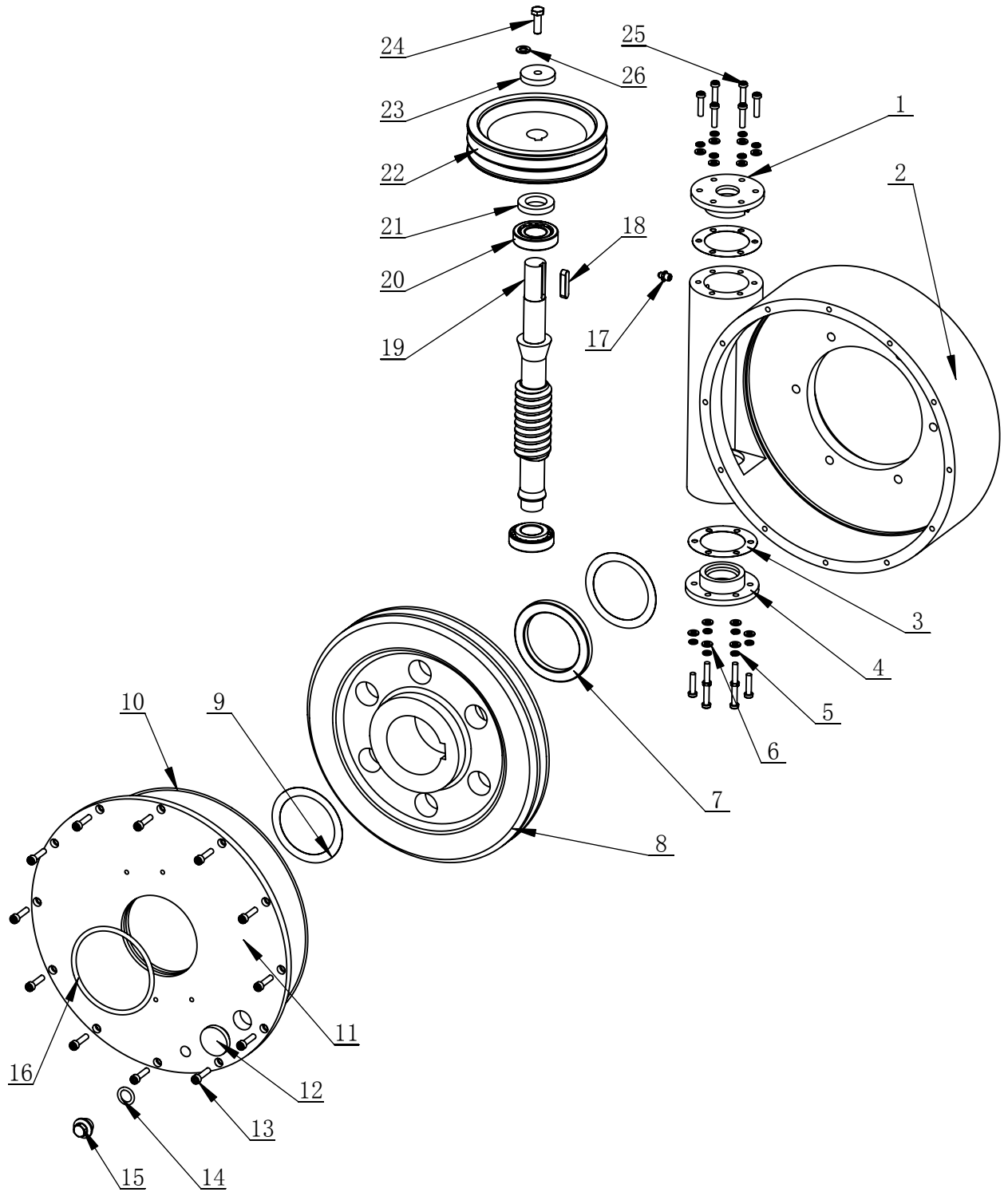

ITEM	QTY.	PART NO.	DESCRIPTION.
1	1	6001041	WORM BOX FRONT TERMINATION
2	1	6001037	WORM BOX
3	2	6001148	PAPER WASHER
4	1	6001039	WORM BOX BACK TERMINATIION
5	12	5010058	WASHER 6
6	12	5000007	WASHER 6
7	1	6001033	MAIN SHAFT ADJUSTING WASHER
8	1	6001034	WORM
9	2	6001032	WASHER
10	1	5000009	O-RING 300X2.65
11	1	6001038	COVER OF WORM BOX
12	1	5500002	OIL DISPLAY M27X1.5
13	12	5006006	SCREW M6X25
14	1	5000011	O-RING 15X3.55
15	1	6001155	BOLT
16	1	5000013	O-RING 100X5.3
17	1	5000012	OIL CUP M8X1
18	1	5000014	KEY 8X40
19	1	6001040	WORM SHAFT
20	2	5000015	BEARING 30205
21	1	5000016	SEALING WASHER W42X25X7
22	1	6001042	LARGE BELT PULLEY
23	1	6001043	CIRCLIP
24	1	5000019	BOLT M8X25
25	12	5000017	SCREW M6X25
26	1	5000018	WASHER 8

6001071 ELECTRICAL CABINET ASSEMBLY

REVISION A-07

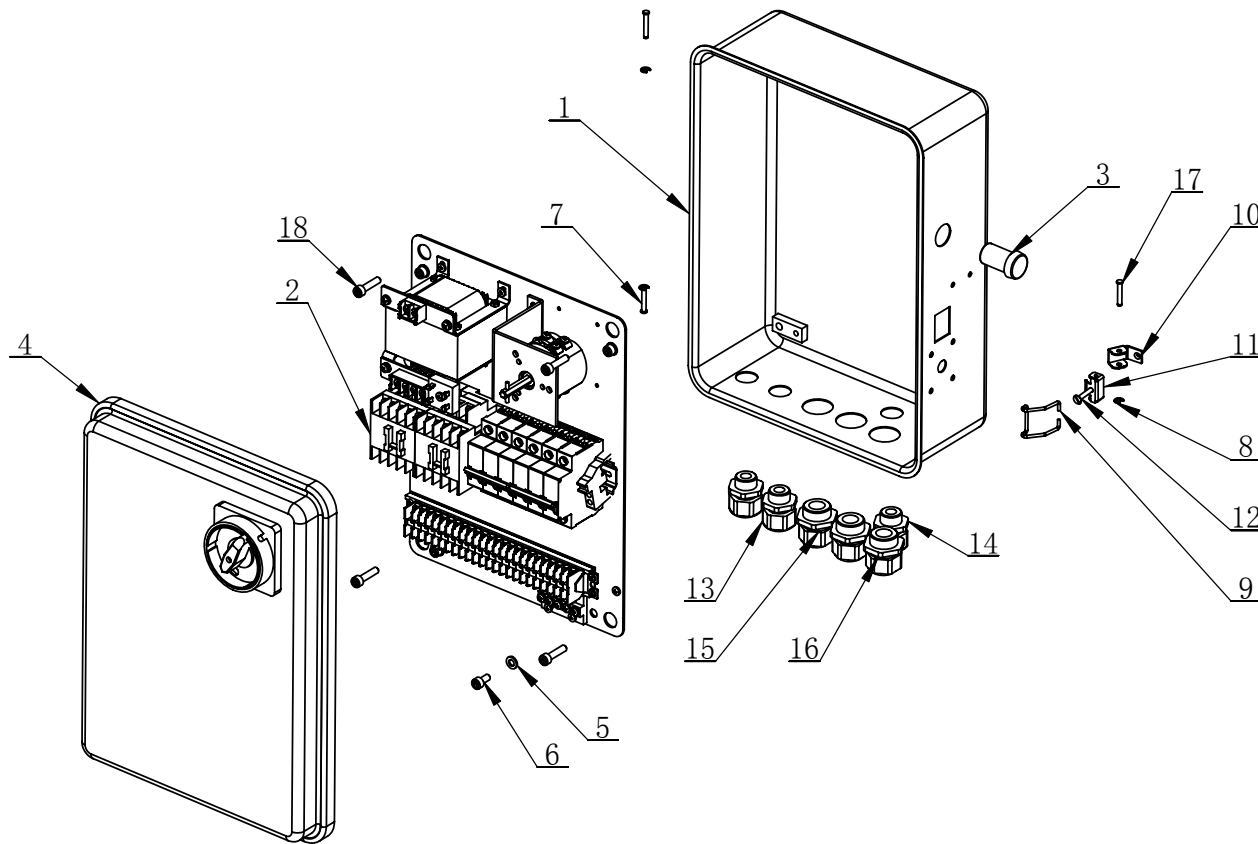

ITEM	QTY.	PART NO.	DESCRIPTION.
1	1	5901100	ELECTRICAL CONTROL CABINET
2	1	5880901	ELECTRICAL
3	1	5500056	INDICATING LIGHT AD16-22D
4	1	5901200	ELECTRICAL CABINET WELDING
5	4	5008063	WASHER 6
6	4	5004001	SCREW M6X12
7	2	5901006	LONG PIN
8	3	5002068	RING 4
9	1	5901003	HINGE NOSE
10	1	5901004	DOOR LOCK ELBOW
11	1	5901002	HINGE NOSE BASE
12	1	5002069	SCREW M4X30
13	2	5500058	CABLE LOCK M18X1.5
14	1	5502089	CABLE LOCK HEAD M20X1.5
15	2	5500062	CABLE LOCK M27X1.5 PG21
16	1	5500062	CABLE LOCK M28X1.5
17	1	5901005	SHORT PIN
18	4	5006006	SCREW M6X25

5880901 ELECTRICAL

REVISION A-02

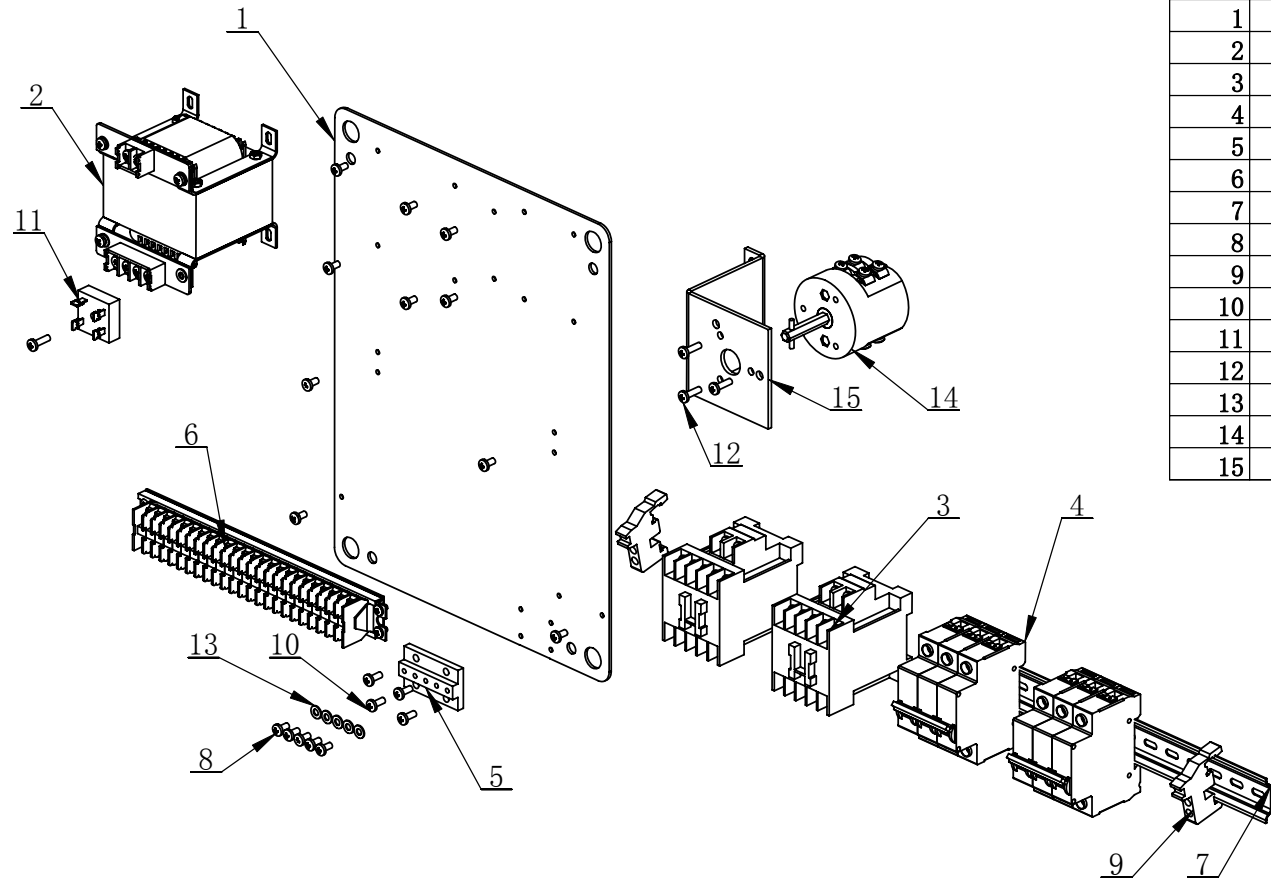

ITEM	QTY.	PART NO.	DESCRIPTION.
1	1	6001833	ELECTRICAL BLOCK BOARD
2	1	5500042	TRANSFORMER ASSEMBLY JBK3-100
3	2	5500051	AC CONTACTOR S-P12
4	2	5500052	TRI-POLE CIRCUIT BREAKER
5	1	6001081	GROUND TERMINATOR
6	1	5500127	LINE BANK ASSEMBLY
7	1	5500046	LONG FIXED PLATE 35mm
8	15	5009007	SCREW M4X8-8
9	2	5500053	FIXTURE CLAMP
10	4	5000010	SCREW M4X10
11	1	5500049	RECTIFIER BRIDGE BLOCK KBPC-2510
12	4	5000098	SCREW M4X14
13	5	5008069	SMWC 4
14	1	5500048	COMBINED SWITCH
15	1	6001835	SWITCH HOLDER

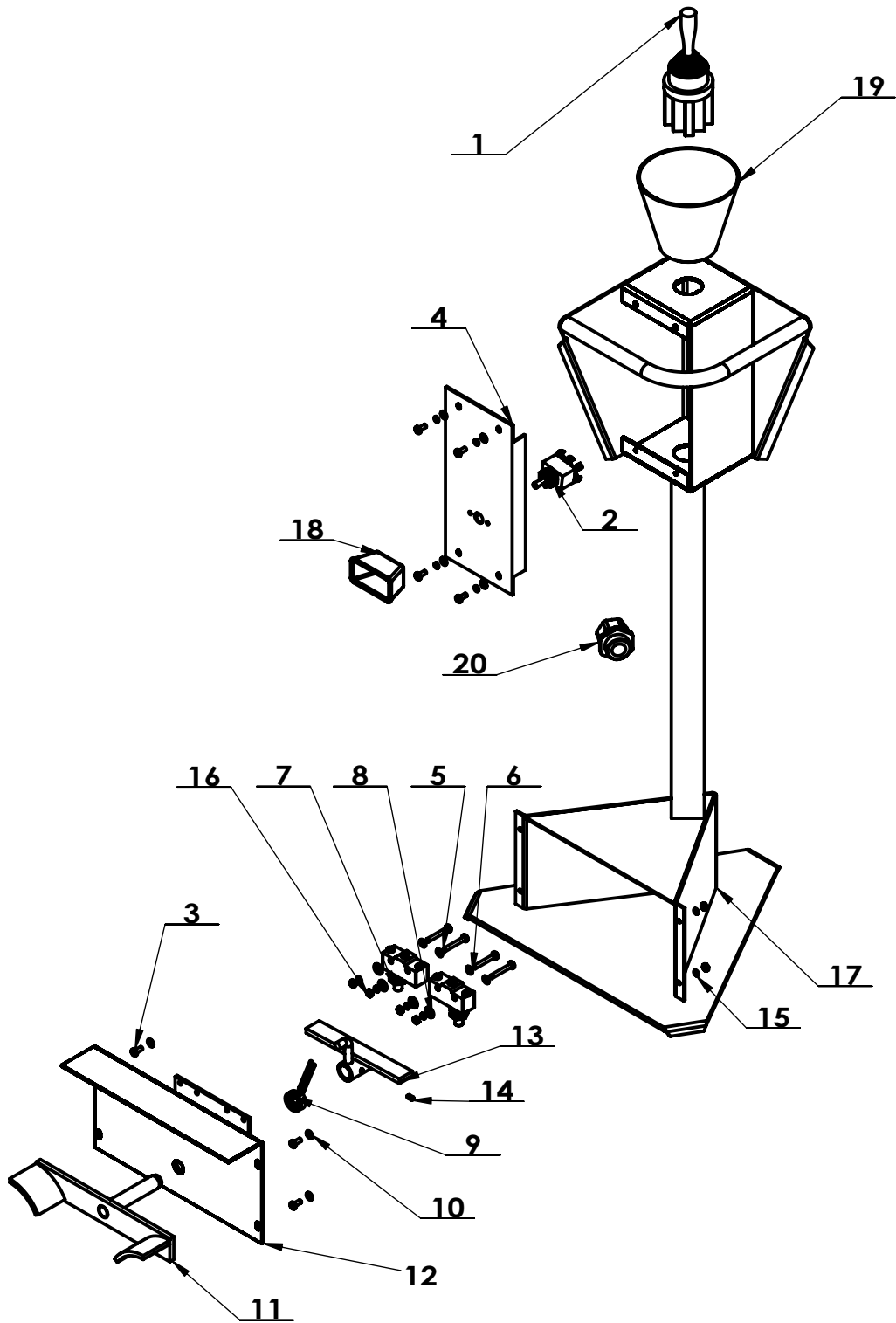

ITEM	QTY.	PART NO.	DESCRIPTION.
1	1	5500003	CROSS SWITCH TMRN-30
2	1	5500004	TORSION SWITCH E-TEN
3	8	5000010	SCREW M4X10
4	1	6001086	COVER
5	4	5000031	SCREW M4X30-N
6	4	5010040	WASHER 4
7	2	5500005	MICROSWITCHE
8	5	5004049	WASHER 4
9	1	5500100	TORSION SPRING
10	8	5010122	WASHER 4
11	1	6001160	SHIFT DIRECTION SHAFT
12	1	6001501	BRACKET
13	1	6001502	SHIFT DIRECTION BUSHING
14	1	5000069	SCREW M4X8
15	12	5000068	WASHER 4
16	8	5000063	NUT M4
17	1	6001500	OPERATION TABLE
18	1	5500063	PROTECTIVE COVER
19	1	6001158	TORSION SWITCH PROTECTION COVER
20	1	5500062	CABLE LOCK M28X1.5

6001098

TAILER ASSMBLY DRAWING

REVISION A-18

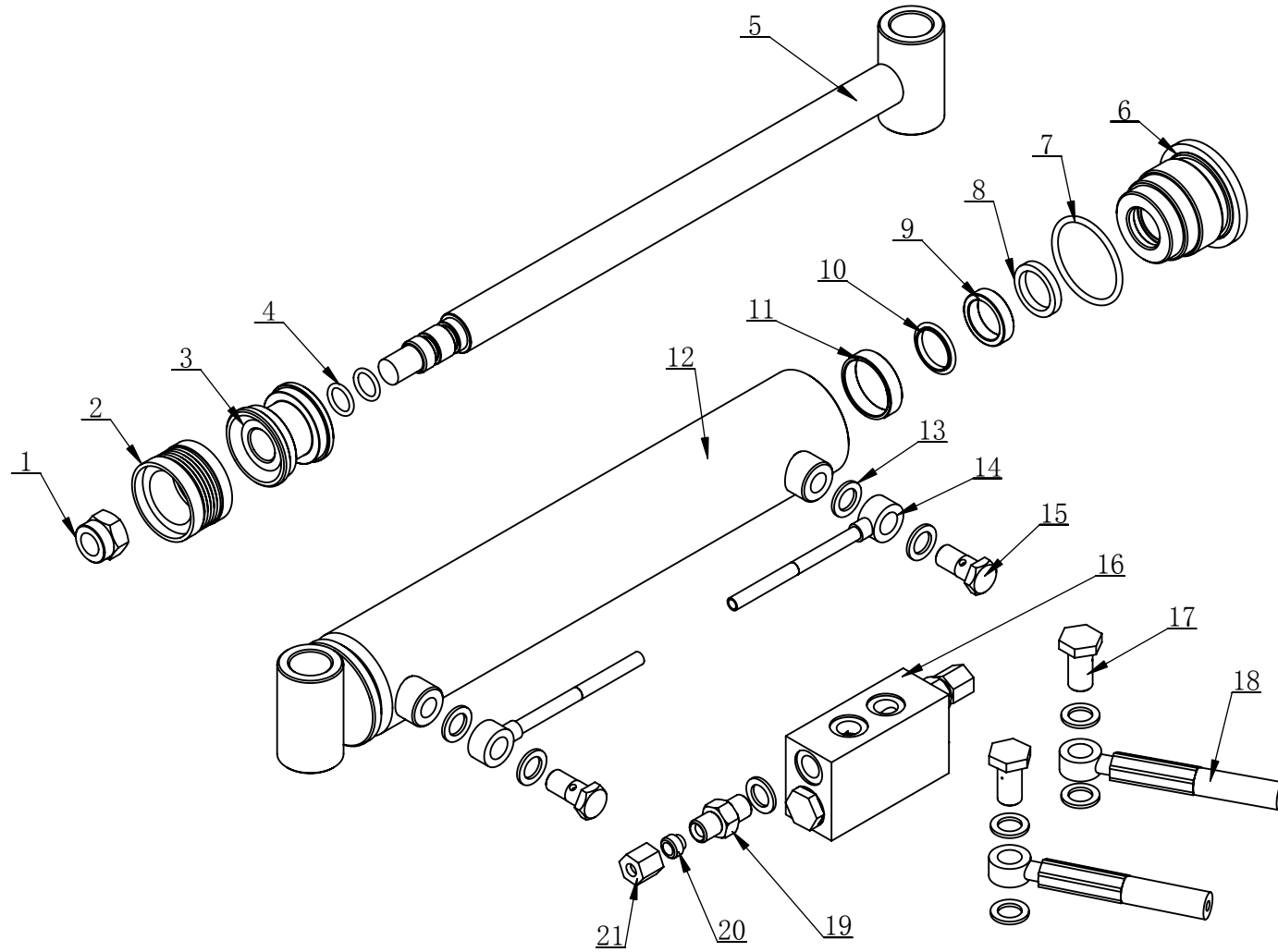

ITEM	QTY.	PART NO.	DESCRIPTION.
1	1	5000050	NUT M16X1.5
2	1	5500036	PTEE L43
3	1	6001104	PISTON
4	2	5500035	O-RING 48.7x3.55
5	1	6001105	PISTON ROD
6	1	6001108	DIRECTION BUSHING
7	1	5500035	O-RING 48.7x3.55
8	1	5500034	DUST-PROOF GASKET 25x33x5
9	1	5500033	U SEALING RING 25x33x8.2
10	1	5500032	SEALING RING D25
11	1	5500031	SUPPORT RING 25X30X5.6
12	1	6001099	OIL TANK BODY
13	11	5500028	COPPER PAD 22X14X2
14	2	5500014	PRESSURE-PROOF RUBBER HOSE
15	2	6001133	OIL TUBE CONNECTOR JOINTS MOUTH
16	1	5500037	HYDRAULIC LOCK
17	2	6001132	JOINTS MOUTH
18	2	5500030	PREASURE HOSE (B-TERMINATION) L=1200
19	2	6001124	OIL PIPE DOUBLE SCREW ROD
20	2	5500016	CLAMP BUSHING
21	2	6001125	NUT-LOCK

6001109 SHAFT RETAINING WASHER ASSEMBLY

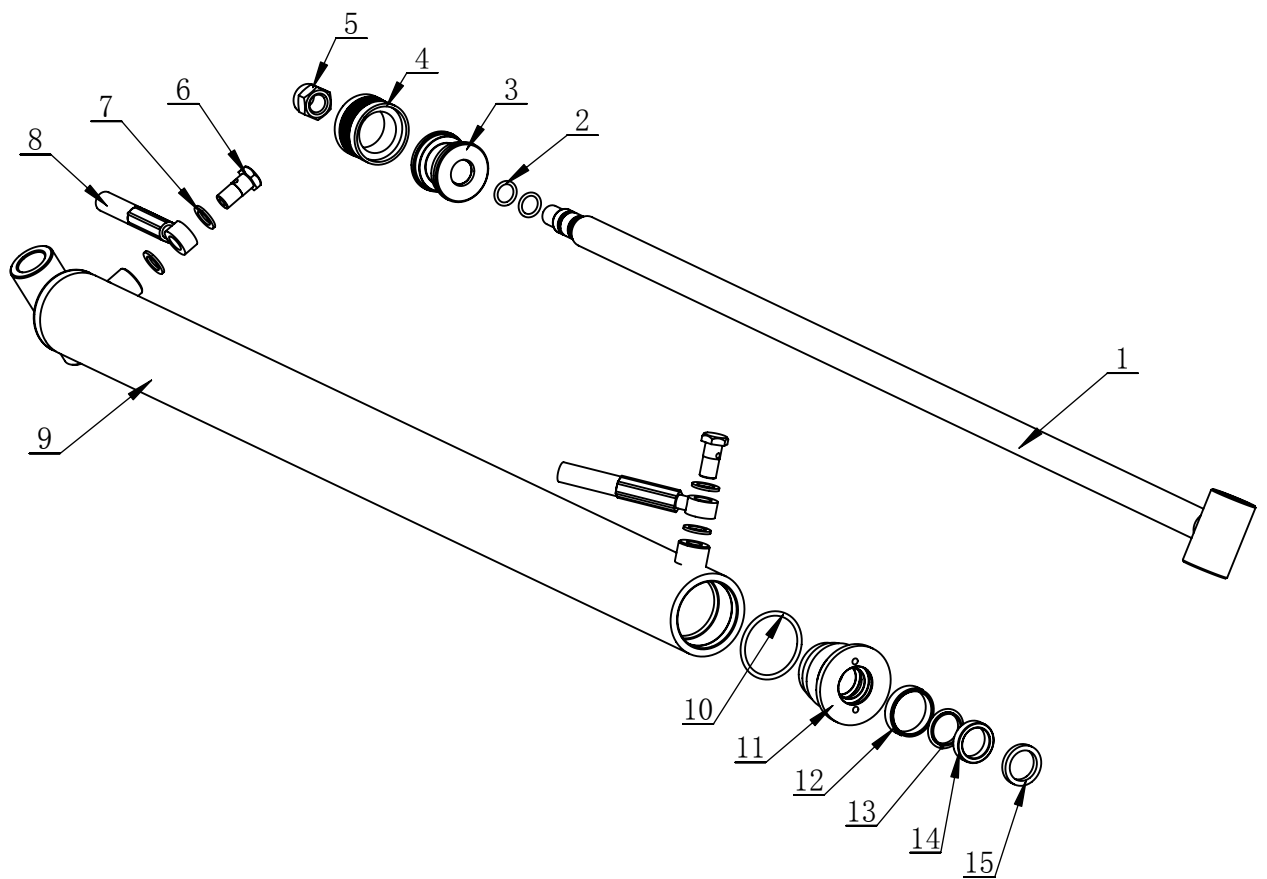

6001109 SHAFT RETAINING WASHER ASSEMBLY

ITEM	QTY.	PART NO.	DESCRIPTION.
1	1	6001114	WELDING PISTON ROD PIECES
2	2	5000046	SEALING RING
3	1	6001104	PISTON
4	1	5000045	SEALING RING
5	1	5000044	NUT-LOCK M16X1.5
6	2	6001133	OIL TUBE CONNECTOR JOINTS MOUTH
7	5	5500028	COPPER PAD 22X14X2
8	2	5500030	PREASURE HOSE (B-TERMINATION) L=1200
9	1	6001110	OIL TANK BODY
10	1	5000043	SEALING RING
11	1	6001108	DIRECTION BUSHING
12	1	5500031	SUPPORT RING 25X30X5.6
13	1	5500032	SEALING RING D25
14	1	5500033	U SEALING RING 25x33x8.2
15	1	5500034	DUST-PROOF GASKET 25x33x5

ITEM	QTY.	PART NO.	DESCRIPTION.
1	1	6001122	PISTON ROD
2	2	5000041	O-RING 24X2.4
3	1	6001121	PISTON
4	1	5500009	SEALING RING
5	1	5000042	NUT M24
6	1	6001123	OIL TANK FRONT COVER
7	1	5500010	Y RING
8	1	5500011	SUPPORT RING
9	1	5500012	GUIDE BELT
10	1	6001117	MAIN SHAFT OIL TANK BODY
11	6	5500028	COPPER PAD 22X14X2
12	1	6001133	OIL TUBE CONNECTOR JOINTS MOUTH
13	1	5500014	PRESSURE-PROOF RUBBER HOSE
14	1	5000036	O-RING 29X3.55
15	1	5500024	OIL GUIDE ONE-WAY VALVE
16	1	5500025	CIRCLIP
17	2	5500026	COPPER PAD 25X18X2
18	1	5500017	OIL GUIDE VALVE CORE
19	1	5500015	PRESSURE GAUGE
20	2	6001124	OIL PIPE DOUBLE SCREW ROD
21	1	5000039	NUT M10
22	2	6001136	OIL ROUTE DOUBLE SCREW ROD
23	2	5500013	A TERMINATION PRESSURE HOUE
24	2	5000040	O-RING 9.5X1.8
25	1	5500023	OIL GUIDE ONE DIRECTION VALVE CORE
26	1	5500027	OIL GUIDE WIRE PLUG
27	6	5000037	O-RING31.5X2.65
28	4	5500019	CIRCLIP
29	1	5500018	OIL GUIDE VALVE CORE
30	5	5000038	O-RING 18X1.8
31	3	5500021	LOCK VALVE SHAFT RETAINING WASHER
32	1	5500022	OIL GUIDE VALVE SHAFT FURREUL
33	1	5500020	OIL GUIDE LOCK VALVE SHAFT
34	2	5000035	SCREW M6X16
35	1	5500016	CLAMP BUSHING
36	1	6001125	NUT-LOCK